

High Current FET Driver

FEATURES

- Totem Pole Output with 6A Source/Sink Drive
- 3ns Delay
- 20ns Rise and Fall Time into 2.2nF
- 8ns Rise and Fall Time into 30nF
- 4.7V to 18V Operation
- Inverting and Non-Inverting Outputs
- Under-Voltage Lockout with Hysteresis
- Thermal Shutdown Protection
- MINIDIP and Power Packages

DESCRIPTION

The UC1710 family of FET drivers is made with a high-speed Schottky process to interface between low-level control functions and very high-power switching devices-particularly power MOSFET's. These devices accept low-current digital inputs to activate a high-current, totem pole output which can source or sink a minimum of 6A.

Supply voltages for both V_{IN} and V_C can independently range from 4.7V to 18V. These devices also feature under-voltage lockout with hysteresis.

The UC1710 is packaged in an 8-pin hermetically sealed dual in-line package for -55°C to $+125^{\circ}\text{C}$ operation. The UC2710 and UC3710 are specified for a temperature range of -40°C to $+85^{\circ}\text{C}$ and 0°C to $+70^{\circ}\text{C}$ respectively and are available in either an 8-pin plastic dual in-line or a 5-pin, TO-220 package. Surface mount devices are also available.

TRUTH TABLE

INV	N.I.	Out
H	H	L
L	H	H
H	L	L
L	L	L

$\overline{\text{OUT}} = \overline{\text{INV}}$ and $\overline{\text{N.I.}}$
 $\overline{\text{OUT}} = \text{INV}$ or $\overline{\text{N.I.}}$

ORDERING INFORMATION

	TEMPERATURE RANGE	PACKAGE
UC1710J	-55°C to $+125^{\circ}\text{C}$	8 pin CDIP
UC2710DW	-40°C to $+85^{\circ}\text{C}$	16 pin SOIC-wide
UC2710J		8 pin CDIP
UC2710N		8 pin PDIP
UC2710T		5 pin TO220
UC3710DW	0°C to $+70^{\circ}\text{C}$	16 pin SOIC-wide
UC3710N		8 pin PDIP
UC3710T		5 pin TO220

BLOCK DIAGRAM

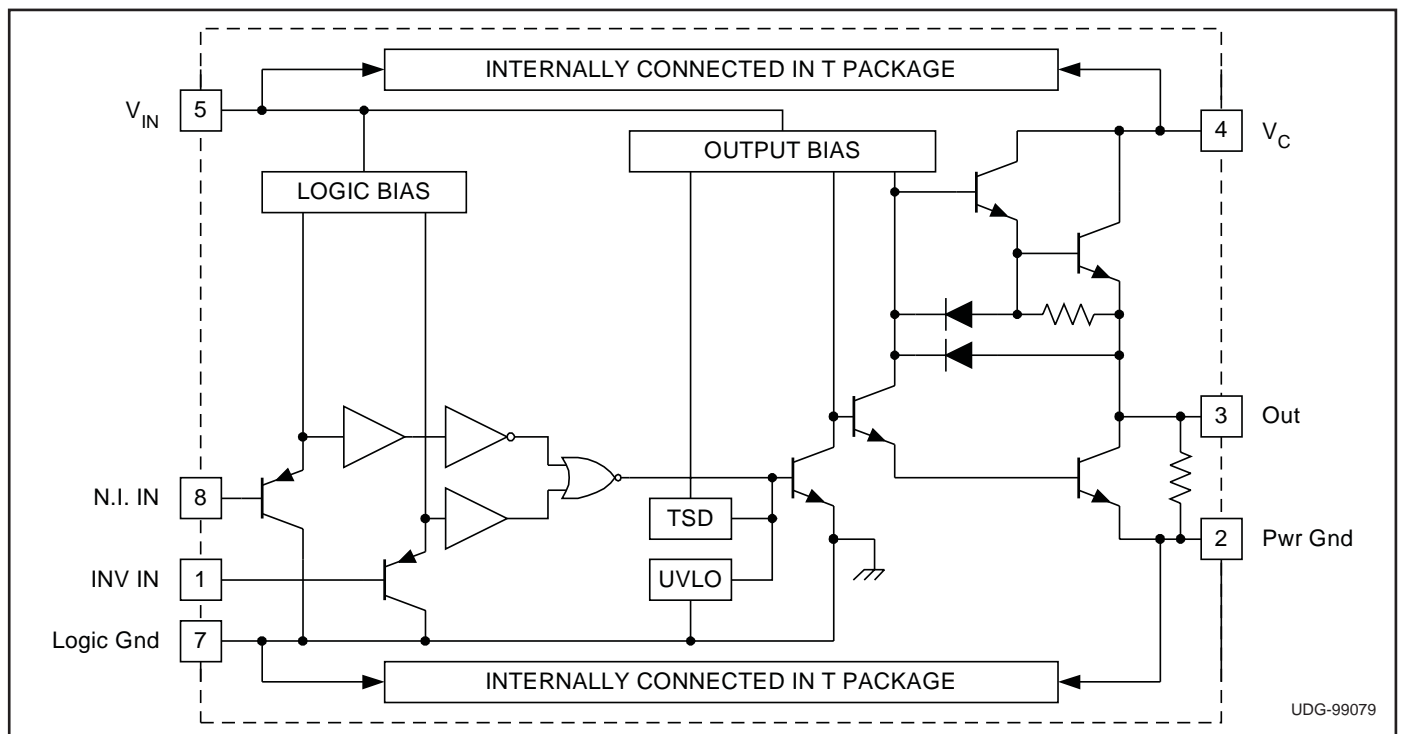

ABSOLUTE MAXIMUM RATINGS

	N-Package	J-Package	T-Package
Supply Voltage, V_{IN}	20V	20V	20V
Collector Supply Voltage, V_C	20V	20V	20V
Operating Voltage	18V	18V	18V
Output Current (Source or Sink)			
Steady-State	$\pm 500\text{mA}$	$\pm 500\text{mA}$	$\pm 1\text{A}$
Digital Inputs	$-0.3\text{V} - V_{IN}$	$-0.3\text{V} - V_{IN}$	$-0.3\text{V} - V_{IN}$
Power Dissipation at $T_a=25^\circ\text{C}$	1W	1W	3W
Power Dissipation at T (Case) = 25°C	2W	2W	25W
Operating Junction Temperature	-55°C to $+150^\circ\text{C}$	-55°C to $+150^\circ\text{C}$	-55°C to $+150^\circ\text{C}$
Storage Temperature	-65°C to $+150^\circ\text{C}$	-65°C to $+150^\circ\text{C}$	-65°C to $+150^\circ\text{C}$
Lead Temperature (Soldering, 10 seconds)	300°C	300°C	300°C

Note 1: All currents are positive into, negative out of the specified terminal.

Note 2: Consult Unitorde Integrated Circuits databook for information regarding thermal specifications and limitations of packages.

CONNECTION DIAGRAMS

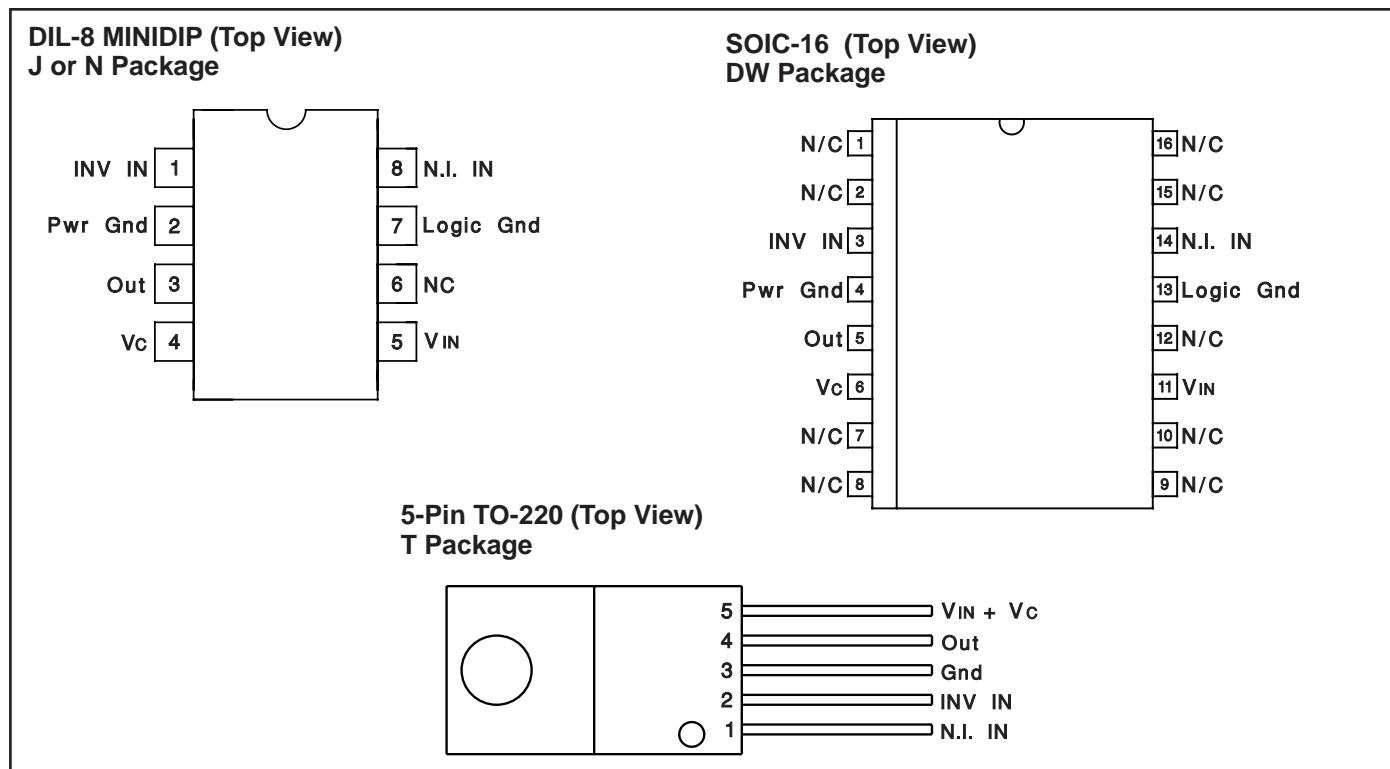

ELECTRICAL CHARACTERISTICS: Unless otherwise stated, these specifications apply for $V_{IN} = V_C = 15\text{V}$, No load, $T_A = T_J$.

PARAMETERS	TEST CONDITIONS	MIN	TYP	MAX	UNITS
V_{IN} Supply Current	$V_{IN}=18\text{V}$, $V_C=18\text{V}$, Output Low		26	35	mA
	$V_{IN}=18\text{V}$, $V_C=18\text{V}$, Output High		21	30	mA
V_C Supply Current	$V_{IN}=18\text{V}$, $V_C=18\text{V}$, Output Low		1.5	5.0	mA
	$V_{IN}=18\text{V}$, $V_C=18\text{V}$, Output High		5.0	8	mA
UVLO Threshold	V_{IN} High to Low	3.8	4.1	4.4	V
	V_{IN} Low to High	4.1	4.4	4.8	V

ELECTRICAL CHARACTERISTICS: Unless otherwise stated, these specifications apply for $V_{IN} = V_C = 15V$, No load, $T_A = T_J$.

PARAMETERS	TEST CONDITIONS	MIN	TYP	MAX	UNITS
UVLO Threshold Hysteresis		0.1	0.3	0.5	V
Digital Input Low Level				0.8	V
Digital Input High Level		2.0			V
Digital Input Current	Digital Input = 0.0V	-70	-4.0		μA
Output High Sat., $V_C - V_O$	$I_O = -100mA$		1.35	2.2	V
	$I_O = -6A$		3.2	4.5	V
Output Low Sat., V_O	$I_O = 100mA$		0.25	0.6	V
	$I_O = 6A$		3.4	4.5	V
Thermal Shutdown			165		$^{\circ}C$
From Inv., Input to Output (Note 3, 4):					
Rise Time Delay	CL = 0		35	70	ns
	CL = 2.2nF		35	70	ns
	CL = 30nF		35	70	ns
10% to 90% Rise	CL = 0		20	40	ns
	CL = 2.2nF		25	40	ns
	CL = 30nF		85	150	ns
Fall Time Delay	CL = 0		35	70	ns
	CL = 2.2nF		35	70	ns
	CL = 30nF		35	80	ns
90% to 10% Fall	CL = 0		15	40	ns
	CL = 2.2nF		20	40	ns
	CL = 30nF		85	150	ns
From N.I. Input to Output (Note 3,4):					
Rise Time Delay	CL = 0		35	70	ns
	CL = 2.2nF		35	70	ns
	CL = 30nF		35	70	ns
10% to 90% Rise	CL = 0		20	40	ns
	CL = 2.2nF		25	40	ns
	CL = 30nF		85	150	ns
Fall Time Delay	CL = 0		35	70	ns
	CL = 2.2nF		35	70	ns
	CL = 30nF		35	80	ns
90% to 10% Fall	CL = 0		15	40	ns
	CL = 2.2nF		20	50	ns
	CL = 30nF		85	150	ns
Total Supply Current at 200kHz Input Switching Frequency	$T_A = 25^{\circ}C$ (Note 5) CL = 0		30	40	mA

Note: 3. Delay measured from 50% input change to 10% output change.

Note: 4. Those parameters with CL = 30nF are not tested in production.

Note: 5. Inv. Input pulsed at 50% duty cycle with N.I. Input = 3V. or N.I. Input pulsed at 50% duty cycle with Inv. Input = 0V.

In no event shall TI's liability arising out of such information exceed the total purchase price of the TI part(s) at issue in this document sold by TI to Customer on an annual basis.

PACKAGING INFORMATION

Orderable Device	Status ⁽¹⁾	Package Type	Package Drawing	Pins	Package Qty	Eco Plan ⁽²⁾	Lead/Ball Finish	MSL Peak Temp ⁽³⁾
5962-0152001QPA	ACTIVE	CDIP	JG	8	1	TBD	A42 SNPB	N / A for Pkg Type
5962-0152001VPA	ACTIVE	CDIP	JG	8	1	TBD	A42	N / A for Pkg Type
5962-0152001VXA	ACTIVE	CDIP	JG	8	1	TBD	A42	N / A for Pkg Type
UC1710J	ACTIVE	CDIP	JG	8	1	TBD	A42 SNPB	N / A for Pkg Type
UC1710J883B	ACTIVE	CDIP	JG	8	1	TBD	A42 SNPB	N / A for Pkg Type
UC1710L883B	OBSOLETE	TO/SOT	L	20		TBD	Call TI	Call TI
UC1710SP	OBSOLETE	CDIP	J	16		TBD	Call TI	Call TI
UC2710N	ACTIVE	PDIP	P	8	50	Green (RoHS & no Sb/Br)	CU NIPDAU	N / A for Pkg Type
UC2710NG4	ACTIVE	PDIP	P	8	50	Green (RoHS & no Sb/Br)	CU NIPDAU	N / A for Pkg Type
UC2710T	ACTIVE	TO-220	KC	5	50	Green (RoHS & no Sb/Br)	CU SN	N / A for Pkg Type
UC2710TG3	ACTIVE	TO-220	KC	5	50	Green (RoHS & no Sb/Br)	CU SN	N / A for Pkg Type
UC3710DW	ACTIVE	SOIC	DW	16	40	Green (RoHS & no Sb/Br)	CU NIPDAU	Level-2-260C-1 YEAR
UC3710DWG4	ACTIVE	SOIC	DW	16	40	Green (RoHS & no Sb/Br)	CU NIPDAU	Level-2-260C-1 YEAR
UC3710N	ACTIVE	PDIP	P	8	50	Green (RoHS & no Sb/Br)	CU NIPDAU	N / A for Pkg Type
UC3710NG4	ACTIVE	PDIP	P	8	50	Green (RoHS & no Sb/Br)	CU NIPDAU	N / A for Pkg Type
UC3710T	ACTIVE	TO-220	KC	5	50	Green (RoHS & no Sb/Br)	CU SN	N / A for Pkg Type
UC3710TG3	ACTIVE	TO-220	KC	5	50	Green (RoHS & no Sb/Br)	CU SN	N / A for Pkg Type

⁽¹⁾ The marketing status values are defined as follows:

ACTIVE: Product device recommended for new designs.

LIFEBUY: TI has announced that the device will be discontinued, and a lifetime-buy period is in effect.

NRND: Not recommended for new designs. Device is in production to support existing customers, but TI does not recommend using this part in a new design.

PREVIEW: Device has been announced but is not in production. Samples may or may not be available.

OBSOLETE: TI has discontinued the production of the device.

⁽²⁾ Eco Plan - The planned eco-friendly classification: Pb-Free (RoHS), Pb-Free (RoHS Exempt), or Green (RoHS & no Sb/Br) - please check <http://www.ti.com/productcontent> for the latest availability information and additional product content details.

TBD: The Pb-Free/Green conversion plan has not been defined.

Pb-Free (RoHS): TI's terms "Lead-Free" or "Pb-Free" mean semiconductor products that are compatible with the current RoHS requirements for all 6 substances, including the requirement that lead not exceed 0.1% by weight in homogeneous materials. Where designed to be soldered at high temperatures, TI Pb-Free products are suitable for use in specified lead-free processes.

Pb-Free (RoHS Exempt): This component has a RoHS exemption for either 1) lead-based flip-chip solder bumps used between the die and package, or 2) lead-based die adhesive used between the die and leadframe. The component is otherwise considered Pb-Free (RoHS compatible) as defined above.

Green (RoHS & no Sb/Br): TI defines "Green" to mean Pb-Free (RoHS compatible), and free of Bromine (Br) and Antimony (Sb) based flame retardants (Br or Sb do not exceed 0.1% by weight in homogeneous material)

⁽³⁾ MSL, Peak Temp. -- The Moisture Sensitivity Level rating according to the JEDEC industry standard classifications, and peak solder temperature.

Important Information and Disclaimer:The information provided on this page represents TI's knowledge and belief as of the date that it is

provided. TI bases its knowledge and belief on information provided by third parties, and makes no representation or warranty as to the accuracy of such information. Efforts are underway to better integrate information from third parties. TI has taken and continues to take reasonable steps to provide representative and accurate information but may not have conducted destructive testing or chemical analysis on incoming materials and chemicals. TI and TI suppliers consider certain information to be proprietary, and thus CAS numbers and other limited information may not be available for release.

In no event shall TI's liability arising out of such information exceed the total purchase price of the TI part(s) at issue in this document sold by TI to Customer on an annual basis.

IMPORTANT NOTICE

Texas Instruments Incorporated and its subsidiaries (TI) reserve the right to make corrections, modifications, enhancements, improvements, and other changes to its products and services at any time and to discontinue any product or service without notice. Customers should obtain the latest relevant information before placing orders and should verify that such information is current and complete. All products are sold subject to TI's terms and conditions of sale supplied at the time of order acknowledgment.

TI warrants performance of its hardware products to the specifications applicable at the time of sale in accordance with TI's standard warranty. Testing and other quality control techniques are used to the extent TI deems necessary to support this warranty. Except where mandated by government requirements, testing of all parameters of each product is not necessarily performed.

TI assumes no liability for applications assistance or customer product design. Customers are responsible for their products and applications using TI components. To minimize the risks associated with customer products and applications, customers should provide adequate design and operating safeguards.

TI does not warrant or represent that any license, either express or implied, is granted under any TI patent right, copyright, mask work right, or other TI intellectual property right relating to any combination, machine, or process in which TI products or services are used. Information published by TI regarding third-party products or services does not constitute a license from TI to use such products or services or a warranty or endorsement thereof. Use of such information may require a license from a third party under the patents or other intellectual property of the third party, or a license from TI under the patents or other intellectual property of TI.

Reproduction of TI information in TI data books or data sheets is permissible only if reproduction is without alteration and is accompanied by all associated warranties, conditions, limitations, and notices. Reproduction of this information with alteration is an unfair and deceptive business practice. TI is not responsible or liable for such altered documentation. Information of third parties may be subject to additional restrictions.

Resale of TI products or services with statements different from or beyond the parameters stated by TI for that product or service voids all express and any implied warranties for the associated TI product or service and is an unfair and deceptive business practice. TI is not responsible or liable for any such statements.

TI products are not authorized for use in safety-critical applications (such as life support) where a failure of the TI product would reasonably be expected to cause severe personal injury or death, unless officers of the parties have executed an agreement specifically governing such use. Buyers represent that they have all necessary expertise in the safety and regulatory ramifications of their applications, and acknowledge and agree that they are solely responsible for all legal, regulatory and safety-related requirements concerning their products and any use of TI products in such safety-critical applications, notwithstanding any applications-related information or support that may be provided by TI. Further, Buyers must fully indemnify TI and its representatives against any damages arising out of the use of TI products in such safety-critical applications.

TI products are neither designed nor intended for use in military/aerospace applications or environments unless the TI products are specifically designated by TI as military-grade or "enhanced plastic." Only products designated by TI as military-grade meet military specifications. Buyers acknowledge and agree that any such use of TI products which TI has not designated as military-grade is solely at the Buyer's risk, and that they are solely responsible for compliance with all legal and regulatory requirements in connection with such use.

TI products are neither designed nor intended for use in automotive applications or environments unless the specific TI products are designated by TI as compliant with ISO/TS 16949 requirements. Buyers acknowledge and agree that, if they use any non-designated products in automotive applications, TI will not be responsible for any failure to meet such requirements.

Following are URLs where you can obtain information on other Texas Instruments products and application solutions:

Products

Amplifiers	amplifier.ti.com
Data Converters	dataconverter.ti.com
DSP	dsp.ti.com
Clocks and Timers	www.ti.com/clocks
Interface	interface.ti.com
Logic	logic.ti.com
Power Mgmt	power.ti.com
Microcontrollers	microcontroller.ti.com
RFID	www.ti-rfid.com
RF/IF and ZigBee® Solutions	www.ti.com/lprf

Applications

Audio	www.ti.com/audio
Automotive	www.ti.com/automotive
Broadband	www.ti.com/broadband
Digital Control	www.ti.com/digitalcontrol
Medical	www.ti.com/medical
Military	www.ti.com/military
Optical Networking	www.ti.com/opticalnetwork
Security	www.ti.com/security
Telephony	www.ti.com/telephony
Video & Imaging	www.ti.com/video
Wireless	www.ti.com/wireless

Mailing Address: Texas Instruments, Post Office Box 655303, Dallas, Texas 75265
Copyright © 2008, Texas Instruments Incorporated